

Pioneering process technology for lithium-ion batteries

Tailored material and particle design

Directly degasified electrode slurries and extrusion mixes

Structured electrode dry mixes

Continuous process and traceable batches

From laboratory to gigafactory



Process technology, that takes your electrode preparation to the next level.



Whether you produce lithium for electric vehicles or develop alternative energy storage systems, Eirich offers the solutions you need throughout the entire electrode production process.

With their unique operating principle, Eirich mixers are used in all kinds of processes: from preparing raw materials for electrodes and coating mediums for separators to wet, semi-dry and dry electrode mixes for anodes and cathodes.

With a network of expert partners, we deliver turnkey systems for everything from raw material preparation to electrode processing. All for the battery cells of today and tomorrow.

As a technology partner with proven expertise in materials and processes, together with years of experience in laboratory and production applications, you can put your trust in us. And we will be happy to help.

Your Eirich battery experts

Pioneering
technology



Content

| | | | |
|------|-------|-------|--|
| Page | 4-5 | _____ | Eirich's unique mixing principle |
| Page | 6-7 | _____ | Lithium-ion batteries – Construction and production process |
| Page | 8-11 | _____ | Eirich along the entire processing chain |
| Page | 12-13 | _____ | Benefit from excellent electrode mixes |
| Page | 14-15 | _____ | MixSolver® – The mixer that makes the difference |
| Page | 16-17 | _____ | Intensive mixers for tomorrow's electrodes |
| Page | 18-19 | _____ | From laboratory to gigafactory |
| Page | 20-21 | _____ | The best from batch and continuous production |
| Page | 22-23 | _____ | Eco-friendly efficiency |
| Page | 24-25 | _____ | Turnkey systems from raw material preparation to electrode mixes |
| Page | 26-27 | _____ | Ready for fully automated processes |
| Page | 28 | _____ | Our battery experts |

Eirich's unique mixing principle

For over 100 years, Eirich mixing technology has proven itself in countless applications in various sectors. As the world market leader in lead-acid batteries, we were among the first to consider the complex tasks involved in the production of lithium-ion batteries. We discovered that our mixers, with their unique operating principle, could be particularly effective here too.

Rotating mixing pan, eccentrically arranged mixing tool

An Eirich mixer is essentially built around three components that can be flexibly adapted to the specific requirements:

- 1 A rotating mixing pan that conveys the material towards the mixing tool.
- 2 An eccentrically arranged mixing tool, whose design, speed and direction of rotation are adjusted to the respective application.
- 3 A bottom/wall scraper that provides additional agitation, supports drainage and prevents deposits on the wall or bottom.

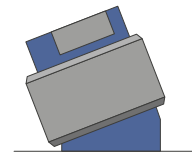

Eirich mixer with inclined mixing pan for mixing, granulating, plasticizing/kneading and coating. In the production of lithium-ion batteries, this intensive mixer can be used just as well for preparing raw materials as for processing electrode dry mixes or extrusion mixes.

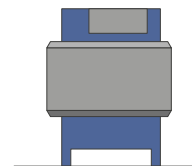

MixSolver® with horizontal mixing pan for the production of high-solid, viscous and paste-like masses, such as electrode slurries.



Expertise in Mixing From 1907 to today

At the beginning of the 20th century, Eirich invented the planetary mixer, a mixer with a static mixing pan and a rotating mixing tool. The company registered the patent for this invention in 1907. Since then, the operating principle behind this mixer has become widespread in the battery industry. But Eirich quickly recognized that the planetary mixer had its drawbacks, specifically the static mixing pan. The mixing principle was quickly modified and in 1924, Eirich presented a new mixer. The Eirich intensive mixer featured a rotating mixing pan and a mixing tool that was arranged eccentrically. This patented functional principle remains relevant to this day.

The early 1990s saw the family-run business become the trendsetter in processing technology for lead-acid batteries with the EVACTHERM® process, which enables simultaneous mixing and cooling under vacuum. It was this innovative process that made it possible to develop the lead-acid battery into the modern "AGM+" battery.

Today, manufacturers of lithium-ion batteries that choose Eirich benefit from the deep knowledge of materials and processes that comes from over 35 years of experience in lead-acid batteries and more than 12 years of experience in lithium-ion batteries.

One machine – multiple options

From granulating, coating and mixing to kneading and dispersing, Eirich mixers can do it all. They process a wide variety of materials in a range of consistencies, delivering excellent results every time. We also offer the MixSolver® with special equipment for economically producing viscous and paste-like masses like slurries.

Benefits of Eirich mixers

- Short mixing time and excellent homogeneity
- 100% material agitation with every rotation of the mixing pan
- Hybrid mixing processes, short mixing time and excellent homogeneity thanks to controllable drives for the mixer and mixing pan
- Economic operation and efficient mixing lead to low energy consumption and minimal wear
- Reliably reproducible product quality and batch times
- Robust design ensures long service life and high availability



Coating



Dispersing



Mixing



Granulating



Plasticizing/
kneading

Lithium-ion batteries – Construction and production process

It was not until the invention of the lithium-ion battery that electrical drives truly became a viable alternative to the combustion engine. Just like other metal-ion batteries, they are constantly being modified and developed further. Although individual steps vary, the overall production process is still organized around electrode processing, cell assembly and cell finishing.

Dynamic development

The first lithium-ion batteries (LiB) were used in consumer electronics in the early 1990s. Today, they can be found everywhere from electromobility and energy storage to large batteries used in industry. But lithium battery technology is still far from reaching maturity. Its development continues apace, not least thanks to Eirich mixing

systems that deliver advantages throughout the production process.

Alternative battery solutions

Innovations in production processes aim to reduce the costs of processing and materials. But developers are also working intensively on the battery cells themselves, which vary in terms of the anode and cathode materials they use. Sodium-ion batteries are just one example of a promising, lithium-free alternative. Here too, Eirich offers solutions for both R&D and production.

Cathode (+)
Aluminum current
collector

Electron



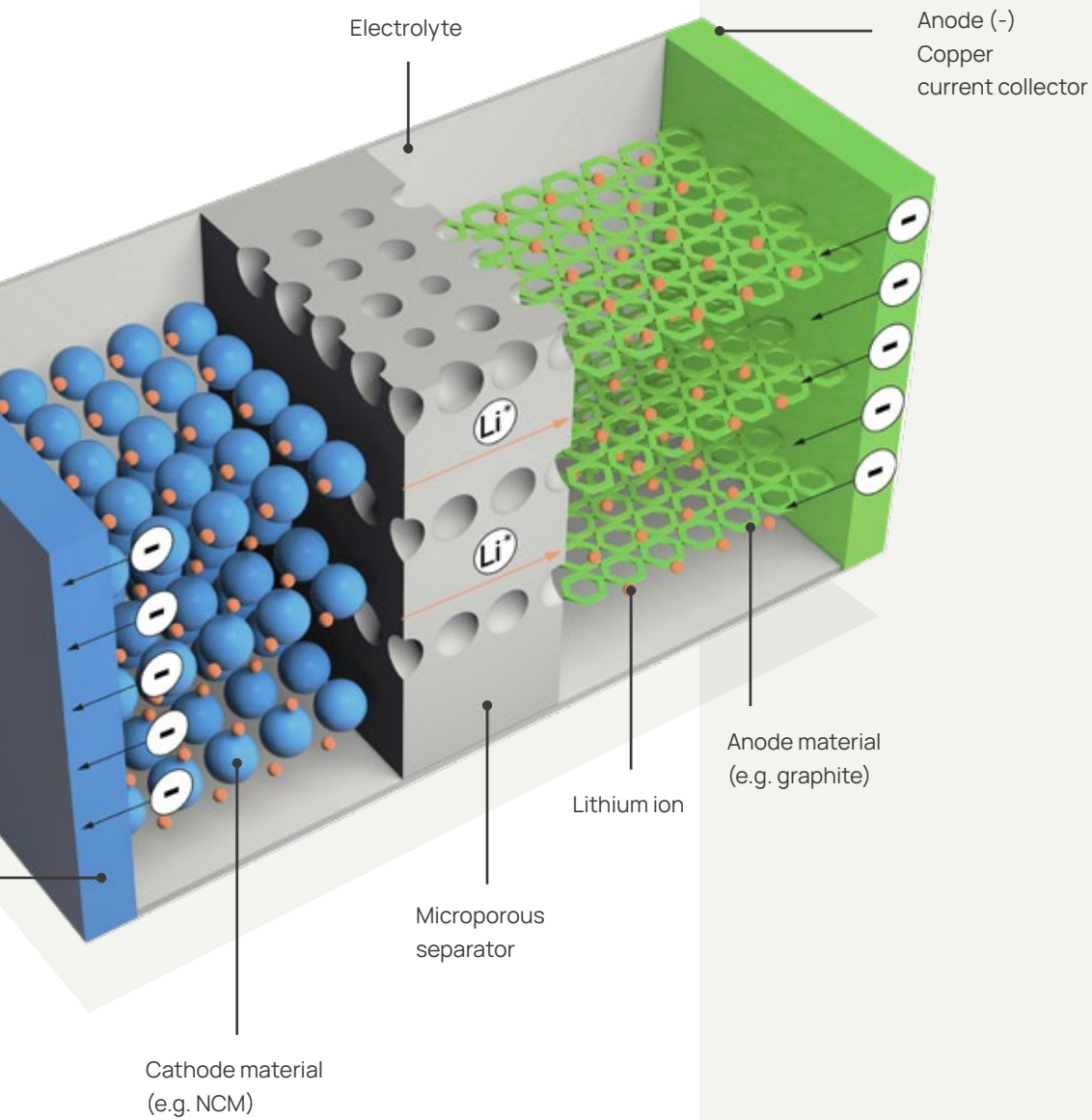

What production steps influence battery quality?

Just like in any other metal-ion battery, the smallest elements of a lithium-ion battery are two electrodes and a microporous separator. Between the electrodes and the separator is an ion-conducting electrolyte.

The structure of the electrode is among the most important factors that affect battery performance. As a battery manufacturer, you can influence the quality of this structure right from the preparation of the raw materials and of course in the processing of the electrode mix.

Electrode processing is followed by cell assembly, in which the batteries are put together and filled with electrolyte. Cell finishing involves the formation and initial charging and discharging of a battery, as well as degasification and maturation if necessary. These process steps also influence cell performance and the service life of the battery.

Eirich along the entire processing chain

From raw material production and the preparation of mixing systems to particle design, the unique operating principle of Eirich mixers opens up a range of interesting options for electrode processing for lithium-ion batteries.

Flexible usage in raw material preparation

Eirich technology lets you combine complex and expensive systems with multiple processing machines in a single process step. The flexibly adjustable energy input that characterizes the Eirich principle makes it possible to use the mixer for dispersing raw materials as well. EvacMix® vacuum mixers deliver much greater homogeneity in ultra-fine materials.

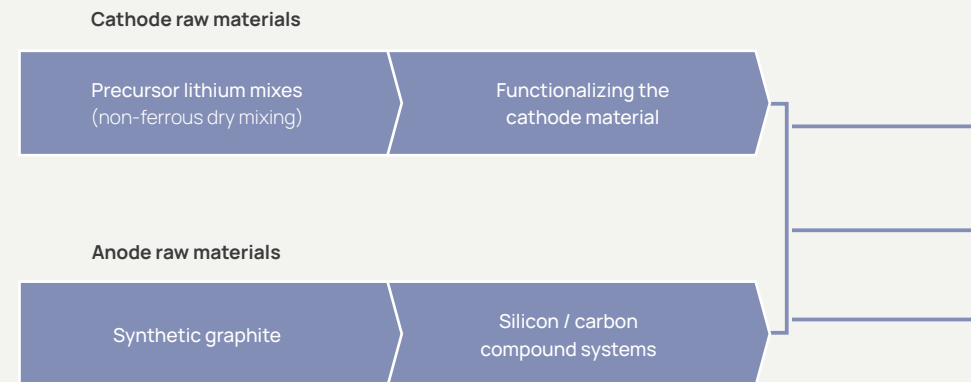

One machine for everything
Excellent wet and dry dispersion

Electrode mix

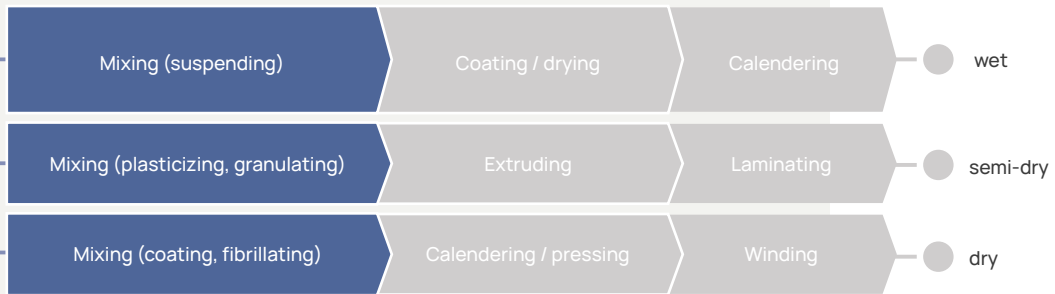

- Eirich processing technology in raw material production
- Eirich processing technology for electrode mixing



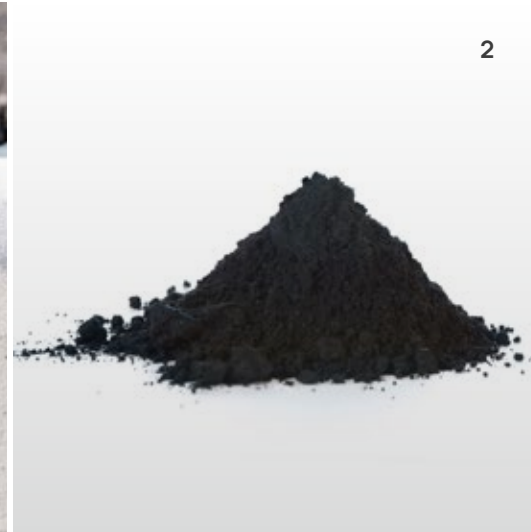

- 1 Weighed input materials
- 2 Synthetic graphite
- 3 Volume expansion through excellent dry dispersion
- 4 Homogeneous mixing of input materials
- 5 Structured dry mix with fibrillated PTFE
- 6 Agglomerated or granulated mixes

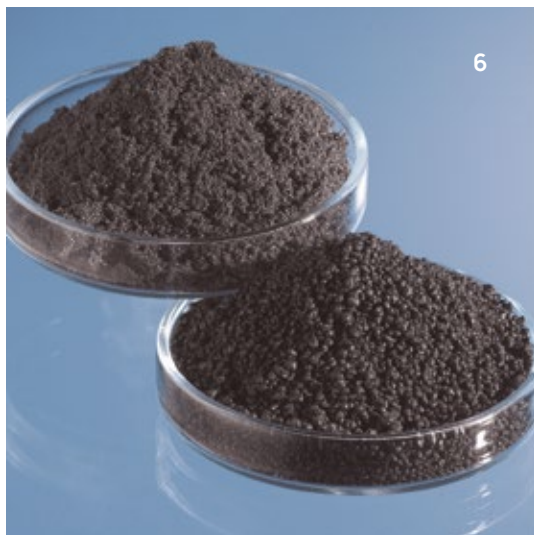
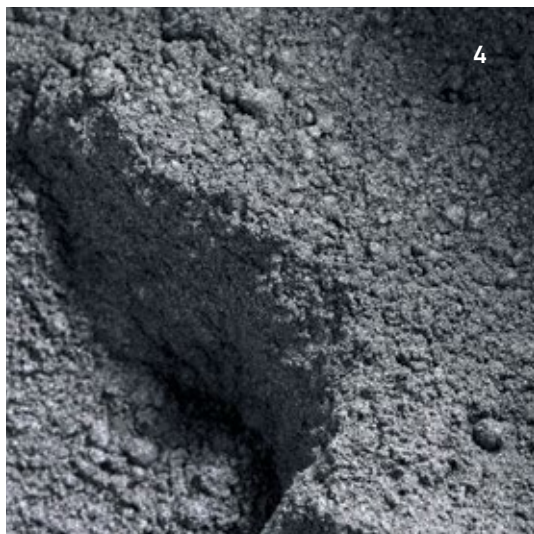

Tailored material and particle design

The Eirich mixing principle enables many different processing steps in the preparation of raw materials for anodes, cathodes and separators, including:

- Wetting/coating of particle surfaces with watery or solvent fluids and/or binding systems
- Dry dispersion of ultrafine raw materials and nanoparticles for producing highly homogeneous mixes
- Solid coating on dry or wet particle surfaces
- Melt coating and granulating of particle systems at temperatures of 35 to 250 °C
- Fibrillation of polymers like PTFE
- Agglomeration and granulation of cathode raw material mixes for active material synthesis (e.g. solid-state systems)
- Graphite production through intensive kneading of carbons with solid or liquid pitches, with mixed product temperatures of up to 250 °C using the patented Eirich induction heating system

Do you want to know more about how Eirich processing technology can help you in electrode mix production? Then keep reading or get in touch.

Benefit from excellent electrode mixes

The quality of the electrodes has a major influence on the performance of lithium-ion batteries. Battery manufacturers are therefore constantly looking for the perfect process for producing electrodes. While wet-processed electrodes were long seen as the standard, semi-dry or dry-processed electrodes are gaining increasing attention. Producers of energy storage cells are also highlighting issues like cost savings and sustainability in manufacturing, while gigafactories are posing all-new challenges.

Always the right solution

Processing systems from Eirich offer solutions that open up a range of opportunities. The ContiFeeder® process using MixSolver® and EvacMix® technology represents a powerful solution for the production and continuous supply of elec-

trode slurry. Alongside this, the intensive mixer is an effective and adaptable alternative for electrode extrusion mixes and structured electrode dry mixes. Clever Eirich solutions like QualiMaster® LiB aid both quality assurance and product optimization here.

From laboratory to gigafactory

As a technology partner with proven expertise in materials and processes, Eirich has many years of experience in mixing systems for LiB electrode mixes. This covers both laboratories and industrial-scale applications, resulting in several benefits that reduce production costs, lower energy consumption and save time.

Get ahead.
Break the limits.

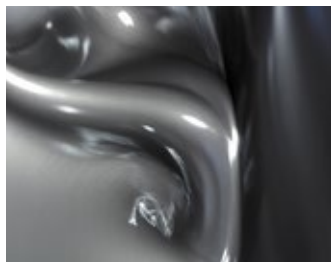
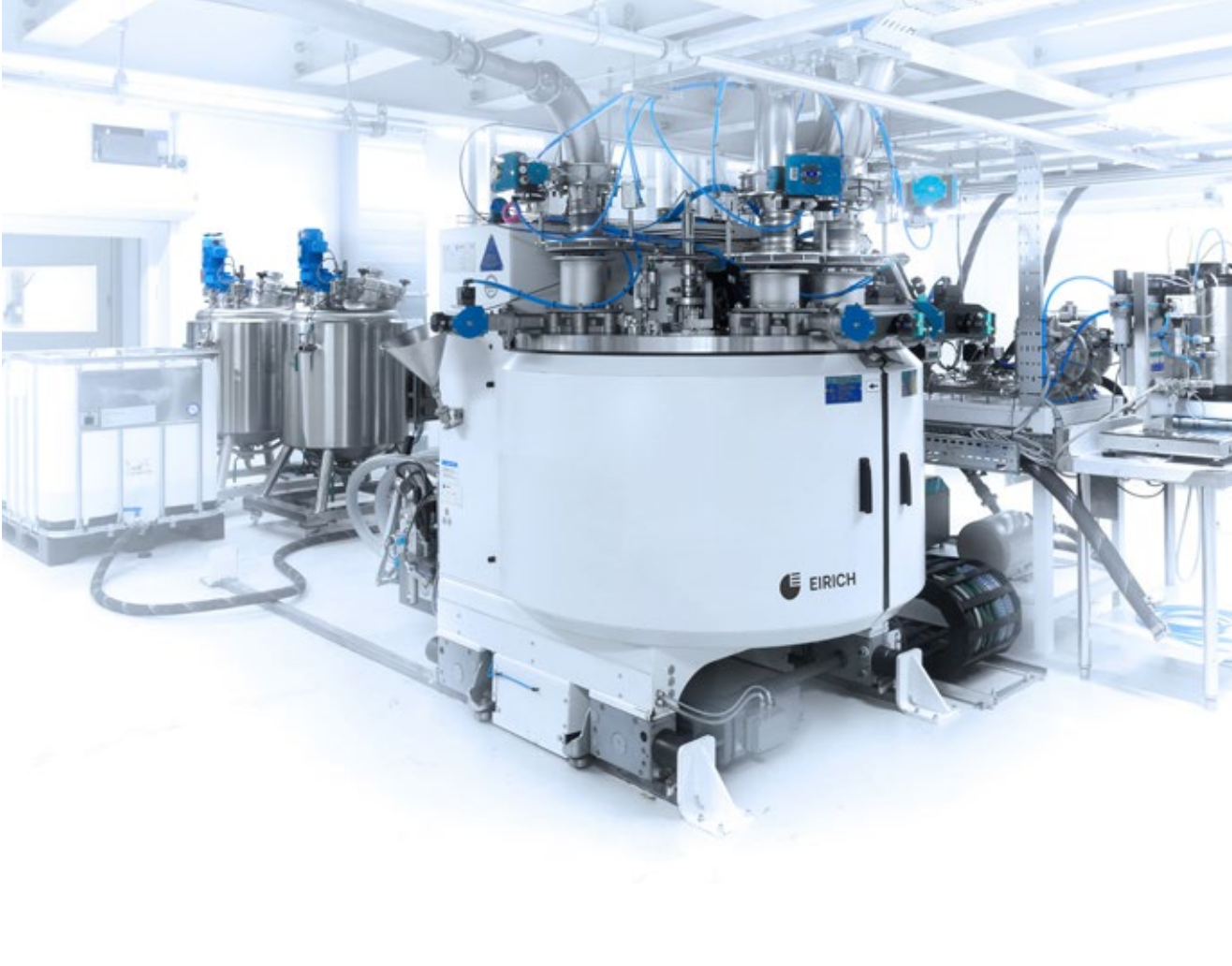

Left to right: slurry, melt-granulated extrusion mix, structured dry mix

Simple scale-up

From laboratory to industrial scale

Sustainable process

Smaller CO₂ footprint, efficient and environmentally friendly

Improved battery performance

Proven mixing technology for reproducible, high-quality results

Clean turnkey solution

Strong partners for dosing and handling

Continuous coater supply

The best from batch and continuous production

Future-ready design

For wet, semi-dry and dry-processed electrodes



Reduce manufacturing costs
Energy savings of up to 95%
Up to 16x faster

MixSolver®

The mixer that makes the difference

The MixSolver® is the heart of Eirich processing technology for slurries. This Eirich mixer is specially tailored to the production of wet electrode mixes. Our intensive mixer differs from conventional mixing systems due to its rotating mixing pan and eccentrically arranged mixing tool.

Greater shear energy input

What makes this product stand out compared to the planetary mixer is the significantly higher shear energy in the high-plastic phase. The higher mixing tool speed and solids concentration in the kneading phase influences the viscosity and quality of the electrode slurries produced. When made in the MixSolver®, they achieve a particularly high and uniform quality with high solid contents.

Directly degasified slurries

We also offer the MixSolver® with EvacMix® technology for directly degasified slurries. Here, the

mixing pan is encapsulated in a pressurized casing. This enables degasification during the mixing process. Versions with double jacket mixing pans for a temperature-controlled process are also available. We also provide the MixSolver® with Ex-protection (ATEX) for processing electrode slurry.

Using process solvent for cleaning

The smart design of the MixSolver® with high-pressure cleaning system keeps waste to a minimum when producing electrode slurry. The solvent used in the process doubles up as a cleaning agent. Any deposits are simply rinsed off, with no need for additional cleaning products. This preserves resources and enables efficient operations around the clock.

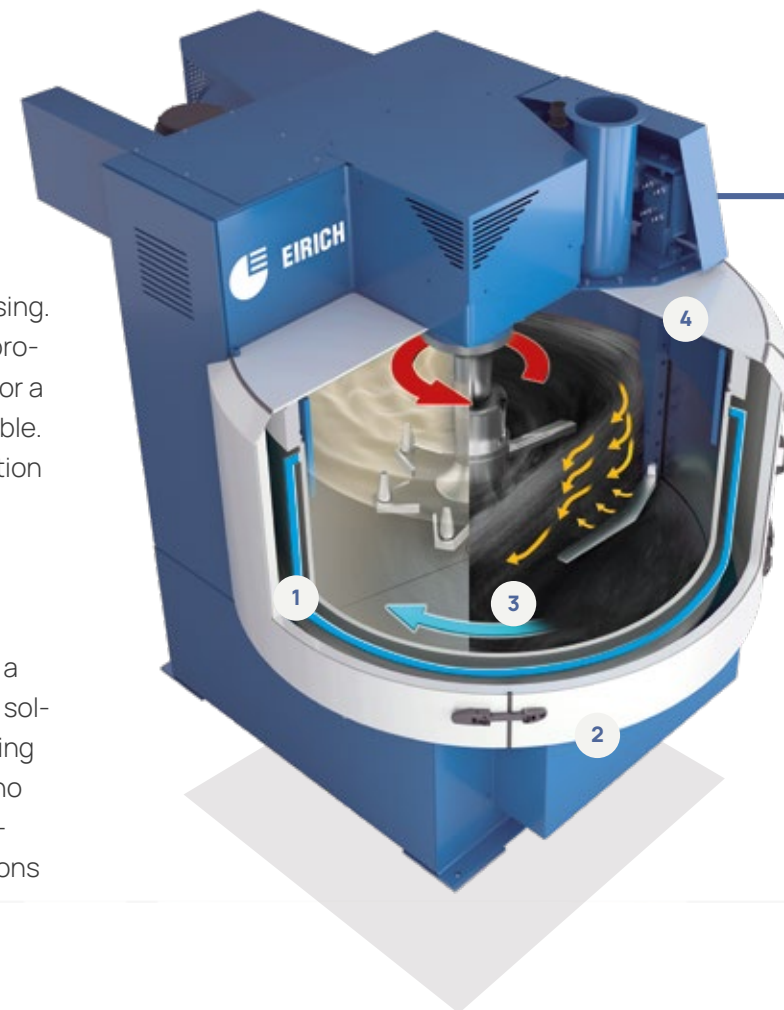



Can Eirich make your batteries better?

Eirich's unique processing systems give you precise control of the carbon network structure and extremely short processing times. This results in outstanding wet and dry dispersion, and better performing batteries.

Would you like to know more?

We look forward to hearing from you.

- 1 Double jacket mixing pan for temperature-controlled process
- 2 Pressurized casing for degasifying slurries under vacuum (with EvacMix® technology)
- 3 Specially patented drainage closure for slurries, standard drainage closure for powdered, granulated or plasticized mixes, or alternatively a vacuum suction system for structured dry mixes and slurries
- 4 High-pressure cleaning system

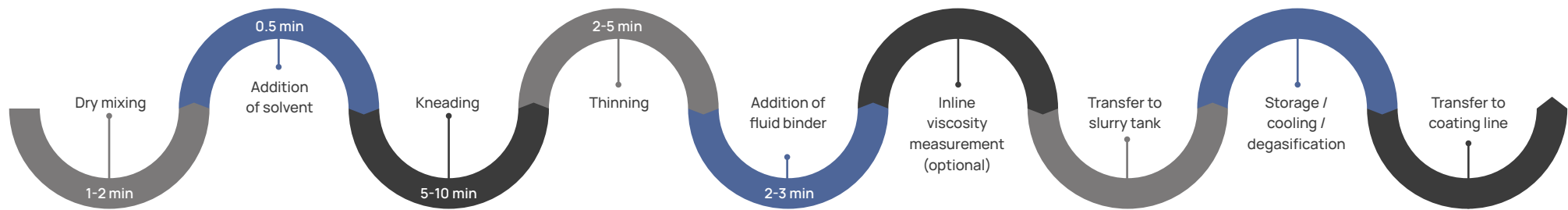

Fast and energy-efficient electrode mix processing

The MixSolver® lets you produce perfectly dispersed electrode slurries in 15-20 minutes. The first step involves intensively mixing all the dry components (active materials, conductive carbon black, binding agents and additives). After adding a sufficient portion of the solvent, the mixture is processed to create a plastic mass. This is intensively sheared over a set period of time at medium to high tool speeds. The powdered binding agent dissolves completely.

In this phase, the choice of operating parameters can significantly influence the quality of the slurry and electrodes. This extrusion mix is then thinned to the required solids content and viscosity. EvacMix® technology makes it possible to degasify the slurry under vacuum in the mixer alongside the production process.



Today and tomorrow

Intensive mixers for tomorrow's electrodes

Dry-processed electrodes are becoming increasingly important, with initial gigafactories based on this concept already being planned. Alongside this, development work is continuing on extruded electrodes and new generations of lithium-ion batteries, as well as alternative systems. Eirich processing technology offers the right solution for every process and battery type.



Intensive mixers for dry-processed electrodes

The operating principle of the intensive mixer is suitable for both preparing the active materials and producing structured electrode dry mixes. No added solvents are required here. As a result, the powdered binding agent is fibrillated, rather than dissolved. This delivers several benefits in the process, such as doing away with the coating and drying process before calendaring the electrodes.

Ready for the batteries of the future

Alternative battery systems are being developed at breakneck pace. Experts see great promise in all-solid-state batteries, in which both the electrodes and the electrolyte consist of solid material. Other alternatives include lithium-sulfur or sodium-ion batteries. Even though these technologies are still far from being market ready, we are certain that Eirich technology will rise to the challenge of these battery types too.

Choosing Eirich mixers today is a decision that will pay off in the future as well, regardless of where the path of battery development goes.



Why does the Eirich intensive mixer also perform well in dry processing?

The Eirich mixer's special operating principle lets it process powders and fluids of any consistency. All it takes to produce dry mixes or even melt-granulated electrode mixes is an adjustment to the operating parameters.

Would you like to know more?

Our team is looking forward to your call.



**Mixing systems
that keep pace with
technological advances**

From laboratory to gigafactory

Eirich mixers can be easily scaled up from laboratory level to a throughput of currently 1,000 l/h per mixer. This lets you transfer the knowledge and experience from research and development to production scale quickly and easily.

Easy recipe adjustment

Once perfected in the laboratory, scaling up the recipe and process developed for the electrode mix to production is simple.

Tailored to special requirements

As a partner with a wealth of project experience, Eirich is constantly developing and adjusting its processes and systems. Our project managers and technicians perfect every single step of the process. Based on the data collected in our test center, we recommend machines, devices and equipment tailored to your specific requirements.

Mixers for all performance classes

From laboratory mixers to combinations of multiple, powerful mixers for gigafactories, Eirich offers the right solution. These give battery cell producers not only an efficient process, but also improved battery performance.



Maximum flexibility
The best result fast

Simple
scale-up

Overview of Eirich mixers

| Type | EvacMix® technology | Ex protection | Glovebox capable | Double-jacket cooling | Capacity in liters | Slurry volume per batch in liters* | Production output in liters/24 h |
|--------|---------------------|---------------|------------------|-----------------------|--------------------|------------------------------------|----------------------------------|
| EL1 | no | no | yes | no | 1 | 0.3 - 0.8 | Lab / development |
| C5 | yes | yes | no | yes | 5 | 1.5 - 4 | Lab / development |
| EL5 | no | no | no | yes | 5 | 1.5 - 4 | Lab / development |
| EL10 | no | no | no | yes | 10 | 3.5 - 8 | Lab / development |
| RL05T | no | yes | no | yes | 40 | 13 - 35 | Lab / development |
| RLV12W | yes | yes | no | yes | 500 | 130 - 500 | Up to 24,000** |

*Depending on raw materials and recipe

**At 500 liters/b, 2 b/h and 24 h/d



Eirich mixer type EL1



Eirich mixer type C5



Eirich mixer type EL5



Eirich mixer type RLV12W

The best from batch and continuous production

A continuous process with just-in-time supply of the downstream steps is an important argument when it comes to selecting processing technology. In slurry processing, the ContiFeeder® ensures just this.

Continuous coater supply

Following the processing of electrode slurries in the MixSolver®, our ContiFeeder® process ensures a continuous feed of high-quality electrode mix. As with processing in continuous mixing systems, the electrode mix is emptied into a slurry tank attached to the mixer after the mixing procedure. This enables additional degasification, temperature control and quality assurance through inline sensors and/or samples.

Excellent traceability guaranteed

The Eirich system therefore ensures that every batch has the required level of dispersion and a homogeneous, unsegregated binder distribution, before the electrode mix reaches the next process step. It is possible to trace the electrode slurry batch for every lithium-ion battery whose electrodes were coated using electrode mixes from Eirich mixers.

Optional “batch-pure” process

If you do not want continuous coater feeding in a system, as is often the case in pilot plants, the electrode mix is emptied into movable slurry tanks. In this “batch-pure” process, the slurry is supplied for the next step on a batch-by-batch basis.

Intermediate storage in buffer tanks

On systems with high throughput rates, the slurry tank into which the electrode mix is fed from the mixer is followed by additional buffer tanks. These serve as intermediate storage and continuously supply the coater with slurry. Users therefore have a better range of options when it comes to batch process quality control, while also enjoying the benefits of continuous coater supply.



“Batch-pure” tanks in a pilot system

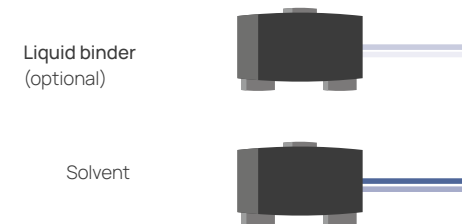

Simplified process
Uniform high quality

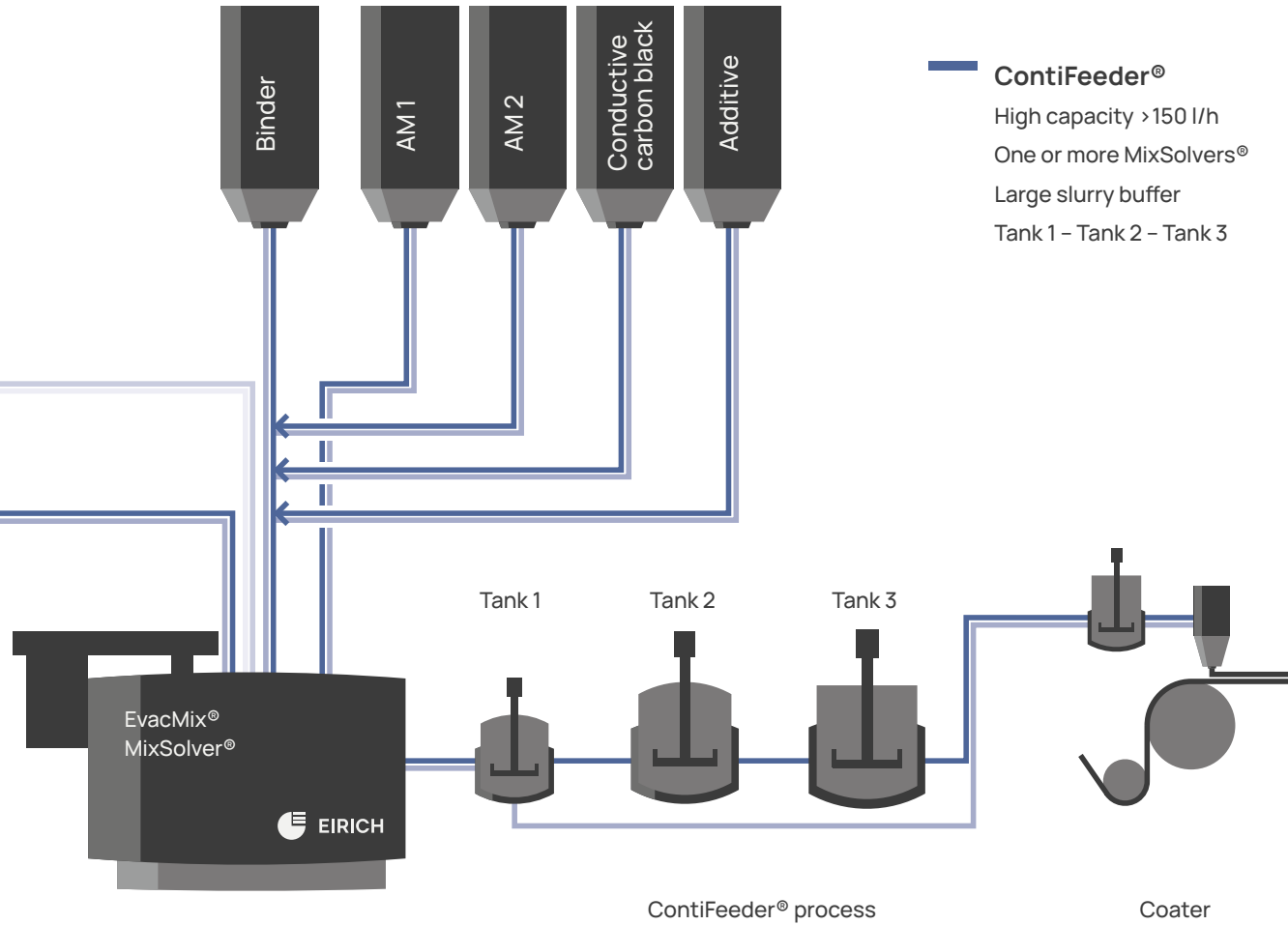

ContiFeeder®
High capacity >150 l/h
One MixSolver®
Small slurry buffer
Tank 1

ContiFeeder®
High capacity >150 l/h
One or more MixSolvers®
Large slurry buffer
Tank 1 – Tank 2 – Tank 3

Is a continuous process possible with electrode dry mixes too?

Eirich has already developed solutions for a wide range of sectors, ensuring continuous material transfer from the Eirich mixer to the subsequent process steps. Rotary table feeders act as both a material buffer and feed device for powdered and crumbly bulk goods. We use them whenever a batch process needs to be integrated or converted into a continuous material flow.

Thanks to our many years of experience in countless industries, we will be sure to offer you the right solution for a continuous process in your battery cell production with dry-processed electrodes. The utmost priority here is ensuring a consistently high electrode mix quality.

Do you have any questions?

We will be happy to provide answers.

Eco-friendly efficiency

MixSolvers® and intensive mixers make the process of producing electrode mixes sustainable. Eirich processing technology is compact and efficient in its use of energy and material.

Excellent electrical consumption values

At a throughput of 20 m³ of slurry per day, for example, a MixSolver® uses just 400 kWh of energy. Electrode slurry produced using Eirich mixers generally requires little to no cooling, therefore saving additional energy. Nevertheless, Eirich offers the MixSolver® with an optional double jacket for a temperature-controlled process. This ensures that the reliable maximum temperature, above which the raw materials could react negatively, is not exceeded.

6-10 GWh plant system
for the production of electrode slurries

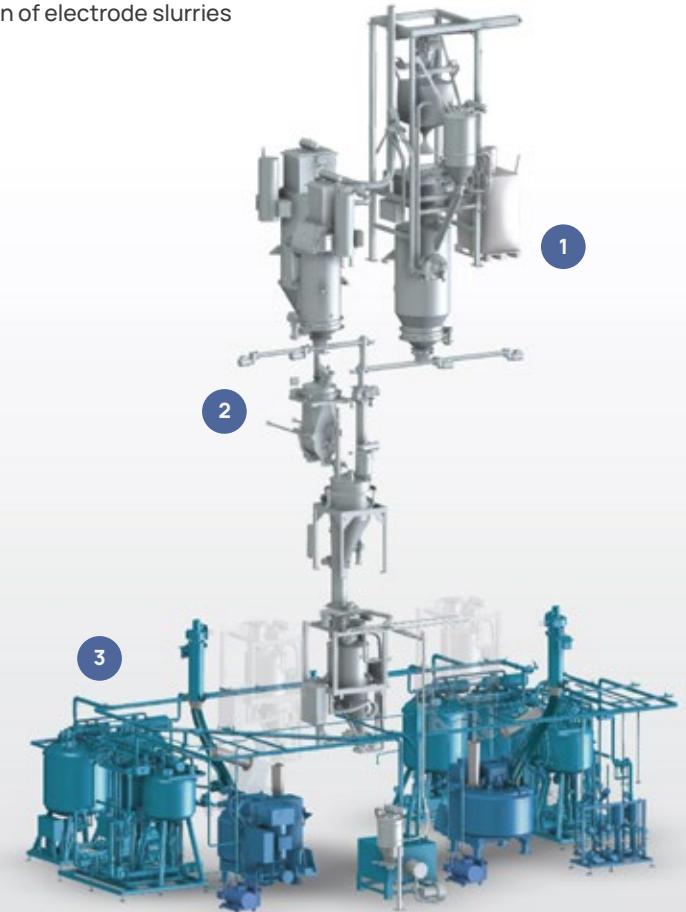

Production line for anode slurry



Do Eirich mixers in gigafactories require less space?

Eirich systems used for processing electrode mixes have a relatively small footprint compared to both plants using planetary mixers and those with continuous mixing systems. One of the main reasons for this is the fact that the plant can be arranged vertically across three levels. A plant for a gigafactory with 13-16 GWh combines three RLV12 Mix-

Solvers®, for example, each with 1,000 l/h of throughput. Each of these mixers features a compact design.

Could this be a solution for you as well?

We would be happy to advise you.



Production line for cathode slurry



Low energy consumption
Small footprint
Resource efficient

- 1 Raw material handling
- 2 Weighing and dosing of all raw materials
- 3 Processing of electrode mixes in one, two or (depending on planned throughput) four MixSolvers® with slurry and buffer tanks

A clean turnkey solution

You need the best expertise available. Eirich has years of experience in both processing raw materials for battery production and the production of everything from electrode slurry to structured electrode dry mixes. To achieve outstanding results, we work together with leading technology partners in ingredient and material handling to deliver a clean turnkey solution. From raw material preparation to coating or an alternative downstream process step, we make sure that production processes make things easier for both the environment and operating personnel.

Dosing system for binders and
conductive additives, along with manual input
station for further additives





Smooth and reliable processes

The expertise of our partners matches perfectly with our own. This ensures smooth and reliable production processes all the way from raw material delivery and safe unpacking to precise dosing and weighing. Plants can also be laid out according to Explosion protection regulations.

One contact partner at all times

Eirich takes a lead role in all phases of the project and acts as your contact partner. We provide mixing, liquid dosing and control systems for the plant, while our partners deliver premium hardware for powder and slurry handling. The result is a turnkey solution tailored precisely to your individual needs. Alongside consulting, planning, production and assembly, Eirich naturally provides a lifetime service for the entire plant.



**Safe processes protect
both staff and
the environment**



Does Eirich supply control and process control systems too?

We develop and produce the machine and process control systems for our mixers in house. All components are configured to match your requirements.

This creates tailored solutions that range from simple machine controls to dosing computers with recipe management. Our controls are complemented by special software packages. These include online documentation with predictive maintenance planning, condition monitoring and remote servicing for your system.

We would be happy to tell you more.

Simply get in touch.



Ready for fully automated processes

Eirich developed the QualiMaster® LiB inline process control system for quality assurance and process optimization. The web-based process visualisation tool ProView®, meanwhile, delivers the perfect overview of all data.

Everything under control

From input materials recorded using barcodes or QR codes to the electrode slurry, we monitor all material flows in the process, allowing us to trace material batches at all times.

QualiMaster® LiB – Perfect quality assurance

Our quality system QualiMaster® LiB is a complete package for inline quality assurance that is available in the Eco, Profi and ProfiPlus variants. This system makes it possible to monitor values like energy consumption, motor power, temperature, pressure and electrode mix viscosity during processing. In the slurry tank or system of slurry and buffer tanks too, the relevant data is recorded and collected via the PLC system. We use the UPC UA communication protocol to guarantee standardized data transfer, even between systems from different manufacturers.

Innovative process data visualization with ProView®

Our web-based process data visualization tool ProView® enables simple and time-saving analysis of the values recorded in the process. This powerful tool makes it possible to compare different batches and simplifies the analysis of the collected data flows. All data is saved in a single database. This is then used for data mining, AI applications or process analysis.

Ready for IoT

With QualiMaster®LiB, ProView® and our control solutions, we provide the ideal conditions for creating an electrode mix processing system that is ready for IoT.

By choosing Eirich, you are choosing engineering that keeps pace with every technological advance.

Are you ready
for IoT?

QualiMaster® LiB

Inline process monitoring
IoT

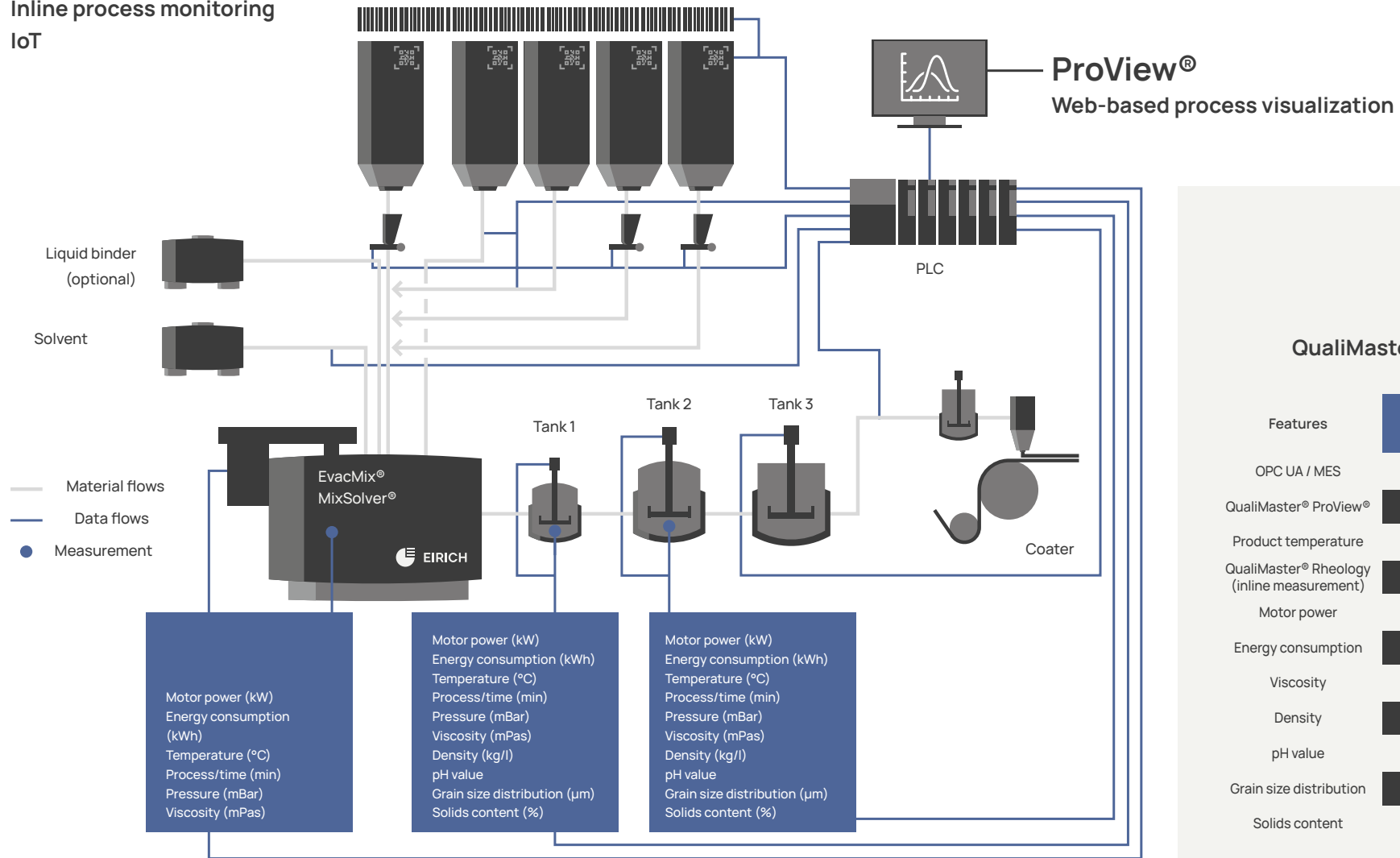

QualiMaster® LiB versions

| Features | Eco | Profi | Profi Plus |
|--|-----|-------|------------|
| OPC UA / MES | ● | ● | ● |
| QualiMaster® ProView® | ● | ● | ● |
| Product temperature | ● | ● | ● |
| QualiMaster® Rheology (inline measurement) | ● | ● | ● |
| Motor power | ● | ● | ● |
| Energy consumption | ● | ● | ● |
| Viscosity | | ● | ● |
| Density | | ● | ● |
| pH value | | ● | ● |
| Grain size distribution | | | ● |
| Solids content | | | ● |

The Eirich Group, with Maschinenfabrik Gustav Eirich as its strategic center in Hardheim, Germany, is a supplier of machines, plants and services for mixing technology, granulating/pelletizing, drying and fine grinding. Our core competences are processes for the preparation of bulk materials, slurries and sludges. We are a family-run company with 13 locations worldwide.

For more information, please visit:

www.eirich.com

Our battery specialists are here to help

Team North America:



Scott Springer

Sales manager - Energy storage
+1 224 419 8970
sspringer@eirichusa.com



Tyler Rhea

Product specialist
+1 224 419 9626
trhea@eirichusa.com

Team Europe:



Dr. Stefan Gerl

Processing specialist
+49 6283 51 374
stefan.gerl@eirich.de



Jürgen Klemke

Sales
+49 151 150 386 73
juergen.klemke@eirich.de



Xiaoyan Sun

Sales
+49 6283 51 670
xiaoyan.sun@eirich.de



Sebastian Berberich

Sales
+49 6283 51 777
sebastian.berberich@eirich.de